

# ExCam<sup>®</sup> IPM1137-LE

---

## User Manual



## Table of contents

<b>1</b>	<b>Introduction</b>	<b>4</b>
<b>2</b>	<b>Technical data</b>	<b>5</b>
2.1	Explosion protection	5
2.2	Illustration of the model key	6
2.3	Electrical parameters of the camera	7
2.4	Cables and glands	7
2.4.1	Connection cable Ex-d - Ex-e PoE	7
2.4.2	Cable glands PoE and protection hose	8
2.4.3	Cable liteServer	8
2.4.4	Cable glands and protection hose liteServer	8
2.5	Video-technical characteristics	8
2.6	Other technical data	8
2.7	Technical specification of the illuminant / LED illumination	9
2.7.1	White light (WL) LED	9
2.7.2	IR-LED	9
2.7.3	Illumination tests	10
<b>3</b>	<b>Safety Instructions</b>	<b>13</b>
<b>4</b>	<b>Installation</b>	<b>15</b>
<b>5</b>	<b>Electrical connection</b>	<b>17</b>
5.1	Potential equalization	17
5.2	Connection work at the device (terminal box) and fuses	18
5.3	External connection and protection	23
5.3.1	Direct routing from the ExTB-3 into the safe area	23
5.3.2	Routing via ExConnection Rail (optional accessories)	24
5.3.3	Appropriate cables & cable entries	25
5.3.4	Fusing	26
5.3.5	Plug assignments (RJ45)	27
5.3.6	Tests prior to switching on voltage	28
<b>6</b>	<b>Working inside the housings (Ex-d)</b>	<b>29</b>
6.1	Preparation for work:	29
6.2	Dismantling the liteServer and the cam adapter	29
6.3	Opening the pressure-resistant housings	30
6.3.1	Opening the camera housing	30
6.3.2	Opening the luminaire housing	32
6.4	Removing / inserting a SD memory card	33
6.5	Hardware Reset	33
6.6	Exchanging the illuminant / LED-block	34
6.7	Closing of the pressure-resistant housing	36
6.7.1	Closing of the camera housing	36
6.7.2	Closing of the luminaire housing	37
6.8	Mounting the adapter and the liteServer	37
<b>7</b>	<b>Network access and visualization</b>	<b>38</b>
7.1	Browser Support	38
7.2	Assigning the IP address	38
7.3	Password/ Identification	39
7.4	Manual or automatic control of the light via the camera	40
7.4.1	Event rule „Manual trigger“	41
7.4.2	Event rule „Motion detection“	42
7.4.3	Event rule „Day-night mode“	43
7.4.4	Event rule „Schedule darkness“	44
7.4.5	E/A-Port Ex.micro	45
<b>8</b>	<b>Maintenance / Modification</b>	<b>46</b>

<b>9</b>	<b>Disposal / Recycling</b> .....	<b>46</b>
<b>10</b>	<b>Drawings, 3D models, certificates and further documentation</b> .....	<b>46</b>

## Table of Figures and Charts

Figure 1-1	Combination camera and luminaire .....	4
Table 2-1	Model key .....	6
Figure 2-1	Sectional view of SKD02-T .....	7
Figure 2-2	Sectional view of ASKD02-T .....	7
Table 2-2	Other technical data .....	8
Table 4-1	Mounting accessories .....	16
Figure 5-1	ExCam IPM1137-LE Potential equalization .....	17
Table 5-1	Potential equalization .....	18
Figure 5-2	ExCam IPM1137-LE-WL T08-VA2.2.K1.BOR-L.H-xxx.N- <b>I</b> .....	18
Figure 5-3	IPM1137-LE-WL T08-VA2.2.K1.BOR-L.H-xxx.N- <b>P</b> .....	18
Figure 5-4	Video Tutorial ExTB-3.....	19
Table 5-2	Wire assignment of terminal box ExTB-2.....	20
Table 5-3	Wire assignment of terminal box ExTB-2/3 (ASKD02-T).....	20
Figure 5-5	Sample circuit of terminal box ExTB-2.....	21
Figure 5-6	Connection to the terminal box .....	21
Figure 5-7	ExTB-3 -> Safe area .....	23
Figure 5-8	ExTB-3 -> ExConnection Rail .....	24
Figure 5-9	Ex-d cable selection .....	25
Figure 5-10	Barrier gland.....	26
Figure 5-11	Plug assignment, RJ45 .....	27
Figure 6-1	Disassembly of liteServer and cam adapter .....	29
Figure 6-2	Removing the weather protection roof .....	30
Figure 6-3	Opening the ExCam IPM1137-LE (similar illustration) .....	31
Figure 6-4	Opening the liteServer®.....	32
Figure 6.5	– Replacing the illuminant .....	34
Figure 6.6	– Removal of the LED block.....	34
Figure 6.7	– Installation of the new LED block .....	35
Figure 6-8	Remounting the liteServer and the adapter .....	37
Figure 7-1	Axis IP Utility .....	39

## History of revisions

Product: ExCam® IPM1137-LE  
 Title: User Manual for ExCam® IPM1137-LE  
 Doc. -Id. 230627-PT08BA-ES-ExCam IPM1137-LE\_en\_rev.00.docx  
 Author: Eva Schneider, Grad. Eng. (UAS)  
 Created on: 27.06.2023

Rev. Index	Date	Name	Comment	Approved by the ATEX Supervisor
0	27.06.2023	E. Schneider	Compilation of the document	

## 1 Introduction

The ExCam IPM1137-LE is a built-in device combination within the T08 ExCam® IPM1137-LE device protection system with the T07-VA2.2.K1.BOR base housing for integrating the Axis M1137 MkII i-CS camera module and another flameproof enclosure (T07-VA0.1) with integrated high-performance LED luminaire to support the illumination of the camera (liteServer Ex.micro). Both Ex d devices are immobile and firmly connected to one another in a defined position by means of a solid stainless steel adapter.

In addition to **5 MP resolution (2592 x 1944)**, the camera offers a **powerful remote zoom vario focus lens** and a **Machine Learning Processing Unit (MLPU)**. It is approved according to Directive 2014/34/EU (ATEX), IECEx and EAC-Ex.

The light: the liteServer Ex.micro is the perfect addition to the camera in areas with poor light. It has a built-in, energy-efficient, long-life LED. This is either cold white or infrared. IR lighting (wavelength 855nm) enables unobtrusive surveillance even in total darkness. The lighting series is approved in accordance with Directive 2014/34/EU (ATEX) and IECEx.

The explosion-proof housing is approved for ATEX group II for zones 1, 2, 21 and 22 including explosion groups IIC / IIIC. For more approvals check our product page [www.samcon.eu](http://www.samcon.eu)

During the development of the ExCam IPM1137-LE, great value was placed on safety, mechanical precision and high-quality stainless steel.

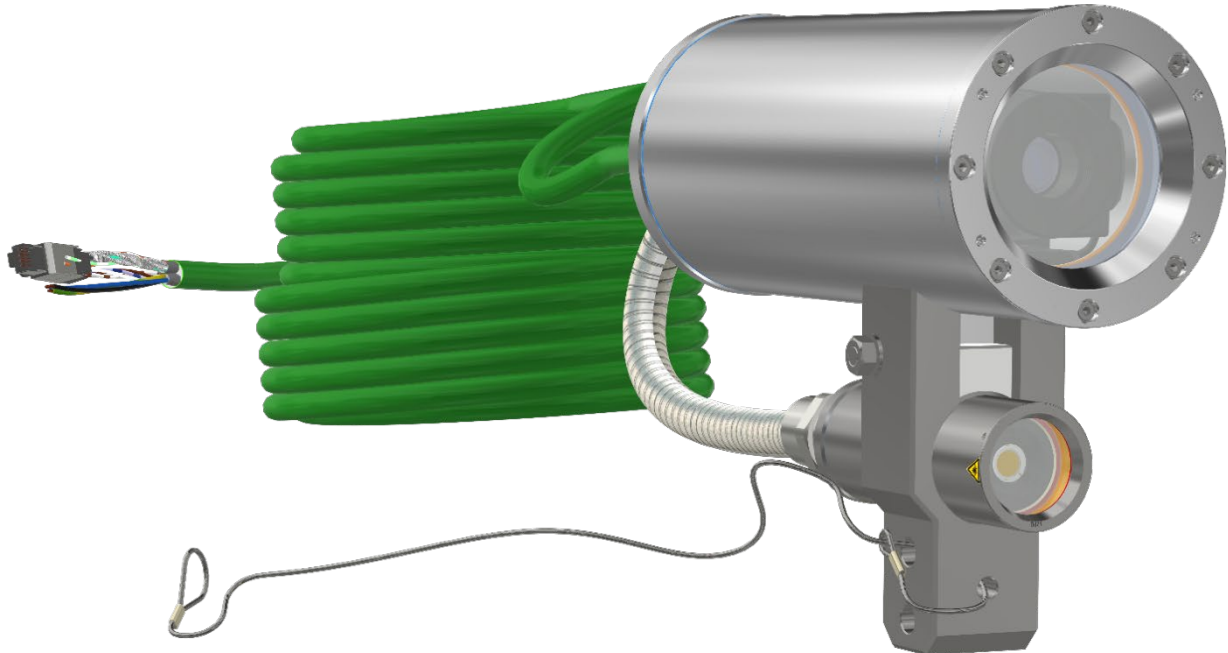

Figure 1-1 Combination camera and luminaire

## 2 Technical data

### 2.1 Explosion protection

Identification marks

acc. to Directive 2014/34/EU:

 II 2G (zone 1 and 2)

 II 2D (zone 21 and 22)

Explosion protection ExCam

Explosion protection (gas):

Ex db IIC T6 Gb

Explosion protection (dust):

Ex tb IIIC T80°C Db

Explosion protection liteServer

Explosion protection (gas):

Ex db IIC T5 Gb

Explosion protection (dust):

Ex tb IIIC T95°C Db

Protection class ExCam:

IP 68 (IEC /EN 60529)

Protection class liteServer:

IP 66/68 (IEC /EN 60529)

Transport/storage temperature:

-40°C...+65°C (non-condensing)

Ambient temperature (EX):

-30°C...+50°C

Named testing laboratory:

TÜV Rheinland (number 0035)

Camera:

EU type approval certificate:

TÜV 18 ATEX 8218X (2018)

IECEX Certificate of Conformity:

TUR 18.0023X (2018)

EAC-Ex TUR Report:

TC RU C-DE.HA65.B.01652/22

Luminaire:

EU type approval certificate:

TÜV 21 ATEX 8696X (2021)

IECEX Certificate of Conformity:

TUR 22.0076X (2022)

Other certificates see:

<https://www.samcon.eu/en/products/network/excam-ipm1137-le/>



**Attention!**

**The instructions stated on the type plates have to be observed!**

## 2.2 Illustration of the model key

Ex product-name		Model variants					Article no.
1)		2) Type	3) Housing- combination	4) Temp.- range	5) Cable length [m]	6) Cable termin.	
ExCam IPM1137-LE	-WL	T08-	VA2.2.K1.BOR-	L.H-	005.N-	P	<a href="#">22070476</a>
	-WL	T08-	VA2.2.K1.BOR-	L.H-	005.N-	T	<a href="#">22070477</a>
	-IR	T08-	VA2.2.K1.BOR-	L.H-	005.N-	P	<a href="#">22070478</a>
	-IR	T08-	VA2.2.K1.BOR-	L.H-	005.N-	T	<a href="#">22070479</a>
(MINING)	-WL	T08-	VA2.2.K1.BOR-	L.H-	005.A-	P	<a href="#">22070501</a>
	-IR	T08-	VA2.2.K1.BOR-	L.H-	005.A-	P	<a href="#">22070502</a>

Table 2-1 Model key

### Explanations:

- 1) ExCam **IPM1137-LE-X** = Functional camera description of the ExCam Series (technical data/ specification of the individual camera module)  
 ExCam IPM1137-LE-**WL** = Functional description of the liteServer Ex.micro neutral white LED  
 ExCam IPM1137-LE-**IR** = Functional description of the liteServer Ex.micro IR LED
  
- 2) **T08** = SAMCON Production- Type 08
  
- 3) **VA2.2.K1.BOR** = T07 ex d housing (stainless steel 1.4404) with large diameter ( $\varnothing_{VA2}=113\text{mm}$ )  
**VA2.2.K1.BOR** = T07 VA2.2 housing with medium body length ( $L_R = 260\text{mm}$ )  
**VA2.2.K1.BOR** = K1 cable gland flange  
**VA2.2.K1.BOR** = Borosilicate sight glass DIN7080 (standard, for video cameras within visible spectral range:  $\lambda = 350\dots2000$  [nm] and photografical infrared range (NIR), not suitable for thermographic applications (MIR/ FIR)
  
- 4) **L.H**= High temperature ( $T_{\text{amb}} < +50^\circ\text{C}$ )  
**L.H**= Low temperatures ( $T_{\text{amb}} > -30^\circ\text{C}$ )
  
- 5) **005.N** = Length of the connection line in meter at delivery; 5m is the standard cable length, max. cable length is: 005...100 [m]  
**005.N** = Non armoured cable  
**005.A** = Armoured cable
  
- 6) **P** = Plug- termination (standard)  
 CAT6, RJ-45 network plug (heavy duty), AWG 26-22, contact assignment acc. To specification EIA/TIA-568B  
**T** = Terminal Box termination (*optional*)  
 4 x PoE Mode A connection (camera PoE)  
 (see chapter electrical connection)

## 2.3 Electrical parameters of the camera

### Power supply of the camera & luminaire:

Voltage supply:	PoE+, IEEE 802.3af/802.3at type 2 class 4
Reference voltage:	+48 V DC (44...54 V DC)
Maximum power consumption:	25.5 W@PoE+
Typical power consumption:	19.5 W

## 2.4 Cables and glands

### 2.4.1 Connection cable Ex-d - Ex-e PoE

Description:	Data transfer and power supply of the camera module (compliant with DIN EN 60079-14)
Jacket colour:	Green (GN), similar to RAL3001
<b>System cable SKD02-T:</b>	
Outside diameter:	8.9 ± 0.3 mm
Bending radius:	8 x D <sub>a</sub> when installed and 4 x D <sub>a</sub> after relocation
Data line:	4 x 2 x AWG23/1 CAT.6
Properties:	PUR halogen-free, flame-retardant, UV-resistant, chemical resistance, shielded
Quick link:	<a href="https://www.samcon.eu/fileadmin/documents/en/60-Assembling%26mounting/SKD02-T_Datasheet.pdf">https://www.samcon.eu/fileadmin/documents/en/60-Assembling%26mounting/SKD02-T_Datasheet.pdf</a>

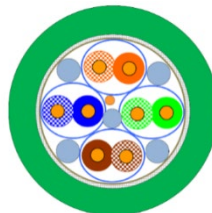

Figure 2-1 Sectional view of SKD02-T

### **System cable ASKD02-T:**

Outside diameter:	12.0 ± 0.4 mm
Bending radius:	20 x D <sub>a</sub> when installed and 10 x D <sub>a</sub> after relocation
Data line:	4 x 2 x AWG23/1 CAT.6
Properties:	PUR halogen-free, flame-retardant, UV-resistant, chemical resistance, shielded (see <a href="http://www.samcon.eu">www.samcon.eu</a> )

Quicklink:

[https://www.samcon.eu/fileadmin/documents/en/60-Assembling%26mounting/ASKD02-T\\_Datasheet.pdf](https://www.samcon.eu/fileadmin/documents/en/60-Assembling%26mounting/ASKD02-T_Datasheet.pdf)

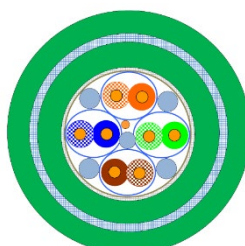

Figure 2-2 Sectional view of ASKD02-T

## 2.4.2 Cable glands PoE and protection hose

System cable SKD02-T → gland Capri ADE1F2 M20x1.5 Cap No.5 (7-12mm)

System cable ASKD02-T → gland Capri ADE4F Cap No.6

[Documentation ADE4F](#), [Declaration of Conformity](#), [Instruction Manual](#), [Datasheet](#)

## 2.4.3 Cable liteServer

### Ölflex HEAT 125MC



[https://www.samcon.eu/fileadmin/documents/de/60-Montage&Installation/OELFLEX-HEAT-125MC\\_Datenblatt.pdf](https://www.samcon.eu/fileadmin/documents/de/60-Montage&Installation/OELFLEX-HEAT-125MC_Datenblatt.pdf)

## 2.4.4 Cable glands and protection hose liteServer

Ölflex heat 125 ML 3G → Ex-d gland ANACONDA Sealite for steel armoured type SU, nickel plated brass for 5/8"

Protective hose

ANACONDA multiflex protective hose, stainless steel armouring

[ANACONDA Documentation](#)

## 2.5 Video-technical characteristics

We use the AXIS M1137 MkII Box Camera in a pressure-resistant enclosure. For details, please refer to the Product Documentation, video-technical data of AXIS®:

<https://www.axis.com/products/axis-m1137-mk-ii>



## 2.6 Other technical data

	Camera (Ex-d)	Luminaire (Ex-d)
Permissible ambient temperature	-30°C ... +60°C	-30°C ... +50°C
Protection class as per EN 60529/IEC 529	IP66/68 (Test conditions: 24h/3m water column 5°C)	IP66/68
Housing material	stainless steel, mat. no. 1.4404	stainless steel, mat. no. 1.4404
Weight	about 7 kg	about 1.4 kg
Dimensions	D113mm x 260mm	D48mm x 127mm

Table 2-2 Other technical data



## 2.7 Technical specification of the illuminant / LED illumination

### 2.7.1 White light (WL) LED

A neutral white high-power COB LED with a **nominal power of 12.5 W** is used in this device as a radiation source for visible light.

The COB LED is characterized by the following technical properties:

LED Type:	COB-LED (InGaN), single phosphor dot, non-matrix arranged, divergent, non-focusing
Power consumption:	12.5W
Max. power consumption:	12.9W@24VDC
Color rendering:	440nm to 690nm
Color temperature:	5000K
Luminous flux:	1930lm
Beam angle:	90°
Dimensions (ØxH):	28 x 2.4 mm

### 2.7.2 IR-LED

A SMD IR-LED with a radiance of **4120 mW** is used in this device as a radiation source for visible light..

The IR LED is characterized by the following technical properties:

LED Type:	High Power 12W IR SMD-LED
Max. power consumption:	13.7W
Infrared centroid wavelength:	850nm
Radiation intensity (IR850):	4120mW
Beam angle:	90°
Operating hours:	50000h



#### **Attention!**

**Infrared radiation emanates from this product. Do not look directly at the operating lamp.**

### 2.7.3 Illumination tests

The external illumination in combination with the ExCam IPM1137 ensures that a good image is obtained up to an object distance of 30.0 m. Even at a distance of 60m, the light intensity is sufficient to be able to recognize an object in the field of vision

The complete documentation of the illumination tests you can find in the document „[ExCam IPM1137-LE Illumination tests Eleonore adit Aslar](#)“.



30m	10m	5m	3m	1m
WIDE WL				
0.7 lx	6 lx	22 lx	55 lx	330 lx
TELE WL				

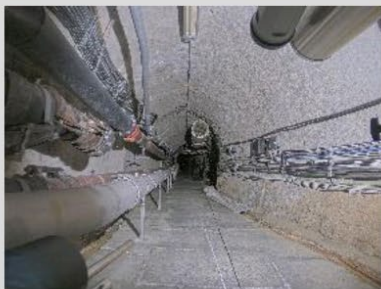



WIDE IR



...W/m<sup>2</sup>



TELE IR

1m

3m

5m

10m

30m

### 3 Safety Instructions

Please absolutely observe the installation instruction's safety directions of the T08 ExCam series and the T20 liteServer series!



Quick link:

<https://www.samcon.eu/fileadmin/documents/en/22-Ex-Network-Cameras/ExCam-Series-T08-EX-Installation-Manual-2020.pdf>

<https://www.samcon.eu/fileadmin/documents/en/40-Lightening-systems/liteServer-Series-T20-Ex-Installation-Manual.pdf>

It is absolutely mandatory to adhere to the national safety regulations and regulations for prevention of accidents, as well as to the safety instructions given below in this User Manual!



**Attention!**

Cameras of type T08 ExCam as well as luminaires of type T20 liteServer are not suitable for use in zones 0 and 20. The ambient temperature, temperature class and explosion group written on the enclosure nameplate must be absolutely adhered to! The customer is not allowed to make any alterations of the devices! The devices must be operated in a proper and sound condition and only in the way intended.



**Attention!**

Repairs may only be carried out by using original parts from the manufacturer. Repairs which affect the explosion protection may only be carried out in accordance with the nationally applied regulations and exclusively by the manufacturer.



**Attention!**

Prior to installation, take external sources of heat or cold into account! The temperature ranges prescribed for storage, transport and operating must be adhered to!



**Attention!**

Adhere to the warnings given on the nameplate:

**“WARNING – DO NOT OPEN IN HAZARD AREAS“**

**Note:** Depending on the classification of hazard areas, a work approval must be obtained. When adjusting the lighting fixture, you shall prevent a potentially explosive atmosphere!



Using the devices in explosion-protected areas with regard to temperature and dust layers is defined in the respective national regulations.



When installing the ExCam and the liteServer, adhere to the requirements of the EN/IEC 60079-14.



**Attention!**

The sight glass must not be directly covered by foreign objects. The light must be able to leave the optics of the protective housing unhindered. Regular cleaning intervals of the sight glass should be observed in order to avoid adhesion and dust deposits.



**Risk of burns from hot surfaces ( $\leq 80^{\circ}\text{C}$ )!**



**Do not stare into the direct beam. Danger of impairment of vision due to high exposure to light!**

**The cable bridge from ExCam to liteServer is preinstalled and must not be changed!**



**The pre-installed RJ45 plug may only be connected in a safe area (non-Ex zone)!**



**The safety rope to protect heavy objects from falling must be attached according to the installation instructions!**

**Prior to the first use, you should test the camera and the luminaire corresponding to the instructions given in the chapter Commissioning.**

**Please observe the national safety regulations and regulations for prevention of accidents, as well as to the safety instructions given below in this User Manual!**

## 4 Installation

For commissioning and operating the camera, the relevant national regulations, as well as the generally accepted rules of technology shall prevail. Before mounting the camera, thoroughly check it for any transport damage, especially on the housing and cable. Installation, electrical connection and the first start must only be carried out by qualified specialists.

### Work preparation:



**Attention!**

**Prepare your work carefully and in accordance with the relevant regulations.**



**Attention!**

**Depending on classification of hazard areas, it is imperative to obtain a work approval first!**

**When you open the pressure-resistant enclosure under voltage, it is absolutely necessary to prevent potentially explosive atmosphere!**

To ensure the best image quality delivered by the network camera, plan the installation site carefully (consider light conditions, object distance or size, angle and minimum object distance to the focus).

- Use appropriate tools and aids.
- When working, ensure a safe stand.
- Make sure that any static charge is avoided.



**Attention!**

**Please observe the national security, installation and accident prevention regulations (e.g. DIN EN 60079-14) and the safety instructions in this User Manual, as well as the ones in the Installation Guidelines!**



**Attention!**

**Adhere to the provisions of the IECEx, ATEX and EX installation instructions for mounting and starting up!**

The ExCam® IPM1137-LE consists of a flame-proof camera housing (Ex-d) and a flame-proof luminaire housing (Ex-d). Both units are connected via a 0.6 m cable. Mount the camera according to the desired field of view. Install the terminal box so that a good accessibility is provided, in order to facilitate electrical connection.



**Attention!**  
 Please pay attention to the national and local regulations for mounting heavy loads. In case of doubt, take appropriate security measures.

Drawings for drill hole patterns and further information can be viewed on our product page:

Quick link:

<https://www.samcon.eu/en/products/network/excam-ipm1137-le/>



### Optional mounting accessories

Wall bracket WMB-...		<p><b>WALL MOUNT BRACKET WMB-VA2.3</b>          Wall bracket for devices of T08-VA2.3 series          Suitable for hanging the camera on walls.          Material: stainless steel 1.4404          Load bearing: 45 kg          Dimensions: 445 x 140 x 185 mm</p>
Weather protection roof WPR-...		<p><b>WEATHER PROTECTION ROOF WPR-VA2.2</b>          Weathershield for cameras of the T08-VA2.2-Series</p>
Pole adapter PMB-...		<p><b>WALL MOUNT BRACKET PMB-VA2.0</b>          Pole adapter for VA wall mount          Material: stainless steel 1.4404          Suitable for pole diameters between 50 and 100 mm          Load-bearing capacity: 50 kg          Dimensions: 120 x 180 (x 130 bei Mast Ø 60 mm)</p>

Table 4-1 Mounting accessories



## 5 Electrical connection



### Attention!

The electrical connection of the equipment may only be carried out by qualified and skilled personnel!



### Attention!

It is absolutely necessary to ground the ExCam® series' housing via the PA connection.



### Attention!

Please observe the national security, installation and accident prevention regulations (e.g. DIN EN 60079-14) and the safety instructions in this User Manual, as well as the ones in the Installation Guidelines!



### Attention!

If possible, carry out initial commissioning when the outside temperature is positive to prevent condensation in the housing.

The delivered ExCam® IPM1137-LE is equipped with an electrical connection cable of the type SKDP03-T. The maximum transmission range from camera to the next active network interface is 100 meters and can be individually specified by the client. The user is NOT authorised to do electrical connection procedures inside the pressure-resistant enclosure.

### 5.1 Potential equalization

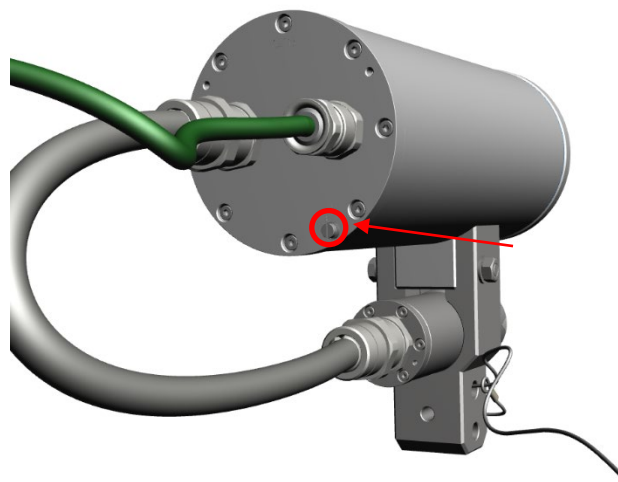

Figure 5-1 ExCam IPM1137-LE Potential equalization

Potential equalization/grounding of the camera housing is absolutely necessary, in order to avoid static charges and thus the formation of sparks. For this purpose, a screw terminal

is provided at the rear side, at the bottom (right) (see Figure 5-1). The cross-section of the potential equalization should comply with the National Ground Rules (at least 4mm<sup>2</sup>).

Wiring table:

Potential	Colour (IEC 60757)	Cross-section	Comment
PA	GN/YE	4 mm <sup>2</sup> (rigid)	Terminal: Slotted screw M4x0.7 (DIN 84) with washer Ø9mm (DIN 125A), Keep 3 Nm tightening torque!

Table 5-1 Potential equalization

## 5.2 Connection work at the device (terminal box) and fuses

### Power supply for the camera (PoE)

Voltage supply:	PoE+, IEEE 802.3at type 2 class 4
Reference voltage:	+48 V DC (44...54 V DC)
Maximum power consumption:	25.5 W@PoE
Typical power consumption camera:	19.5 W
Power consumption luminaire:	12.9 W@24 VDC (WL); 13.7 W@24VDC (IR)

The figures 5.2 and 5.3 illustrate the potential cable terminations of the ExCam IPM1137-LE. Possible terminations are: terminal box or plug.

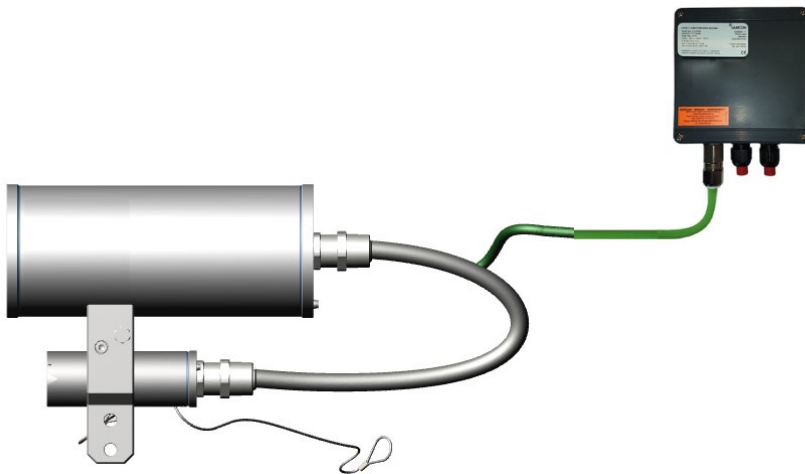

Figure 5-2 ExCam IPM1137-LE-WL T08-VA2.2.K1.BOR-L.H-xxx.N-I

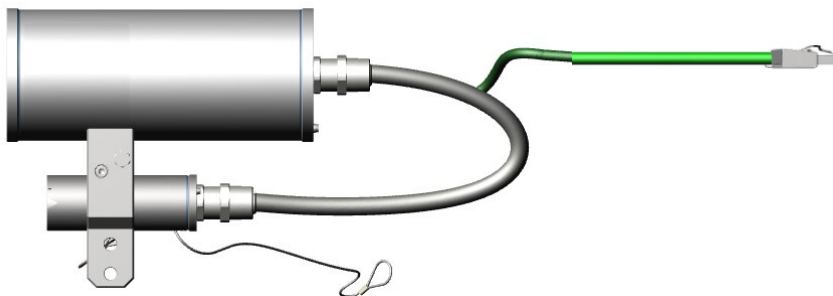

Figure 5-3 IPM1137-LE-WL T08-VA2.2.K1.BOR-L.H-xxx.N-P



**Attention!**  
**Never open the Ex-e terminal box under voltage!**



**Attention!**  
**Adhere to the international installation regulations for connection chambers with increased safety (Ex-e).**



**Attention!**  
**Adhere to attached separate User Manual for the Ex-e terminal box.**

### Video Tutorial:

Observe our video tutorial:

“SAMCON 01 Wiring the cable SKDP03-T to the junction box ExTB-3”  
<https://go.samcon.eu/v01>



Figure 5-4 Video Tutorial ExTB-3

The pin assignment of the SKD02-T is executed in accordance with the standard EIA/TIA-568B as follows:

Camera (Ex-d) (T568B)	Colour SKD02-T (IEC60757)	Terminal ExTB-2	Cross-sectional surface	Comment
Tx+	WH / OG	1	0.26 mm <sup>2</sup>	Solid conductor
Tx-	OG	2	0.26 mm <sup>2</sup>	Solid conductor
Rx+	WH / GN	3	0.26 mm <sup>2</sup>	Solid conductor
Rx-	GN	4	0.26 mm <sup>2</sup>	Solid conductor
(PoE +48 VDC)	WH / BU	5	0.26 mm <sup>2</sup>	Solid conductor
(PoE +48 VDC)	BU	6	0.26 mm <sup>2</sup>	Solid conductor
(PoE GND)	WH / BN	7	0.26 mm <sup>2</sup>	Solid conductor
(PoE GND)	BN	8	0.26 mm <sup>2</sup>	Solid conductor
GND/SHD	YE / GN	PE	2.5 mm <sup>2</sup>	Flex

Table 5-2. Wire assignment of terminal box ExTB-2

The pin assignment of the ASKD02-T is executed in accordance with the standard EIA/TIA-568B as follows:

Camera (Ex-d) (T568B)	Colour ASKD02-T (IEC60757)	Terminal ExTB-2/3	Cross-sectional surface	Comment
<b>Reinforcement</b>	YE / GN	PE	2.5 mm <sup>2</sup>	Flex
Tx+	WH / OG	1	0.26 mm <sup>2</sup>	Solid conductor
Tx-	OG	2	0.26 mm <sup>2</sup>	Solid conductor
Rx+	WH / GN	3	0.26 mm <sup>2</sup>	Solid conductor
Rx-	GN	4	0.26 mm <sup>2</sup>	Solid conductor
(PoE +48 VDC)	WH / BU	5	0.26 mm <sup>2</sup>	Solid conductor
(PoE +48 VDC)	BU	6	0.26 mm <sup>2</sup>	Solid conductor
(PoE GND)	WH / BN	7	0.26 mm <sup>2</sup>	Solid conductor
(PoE GND)	BN	8	0.26 mm <sup>2</sup>	Solid conductor
GND/SHD	YE / GN	PE	2.5 mm <sup>2</sup>	Flex

Table 5-3 Wire assignment of terminal box ExTB-2/3 (ASKD02-T)

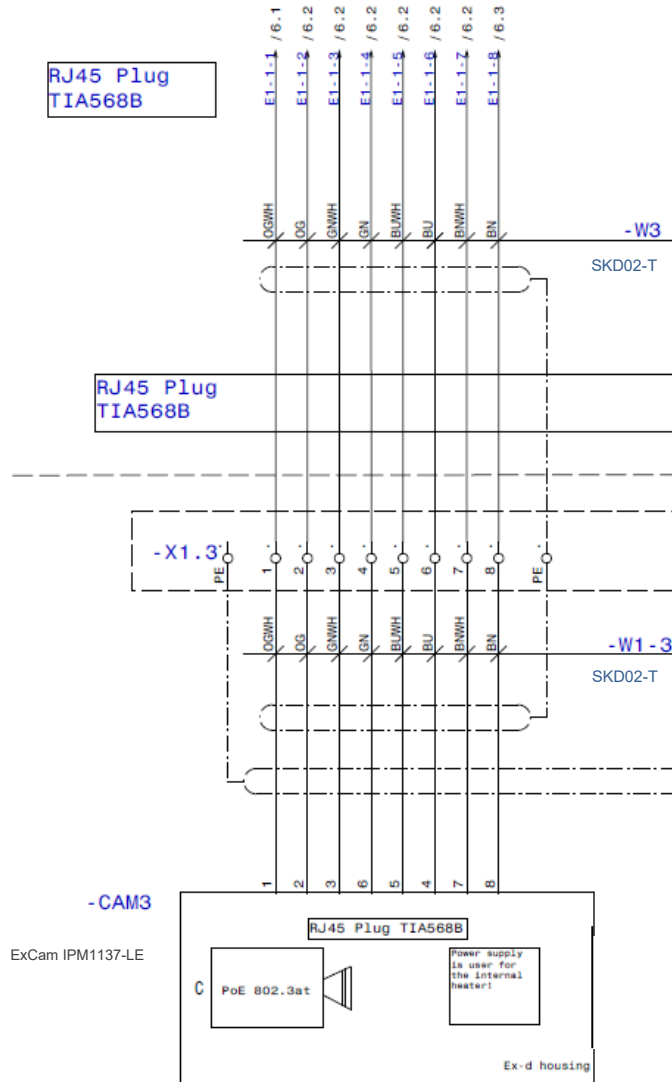

Figure 5-5 Sample circuit of terminal box ExTB-2

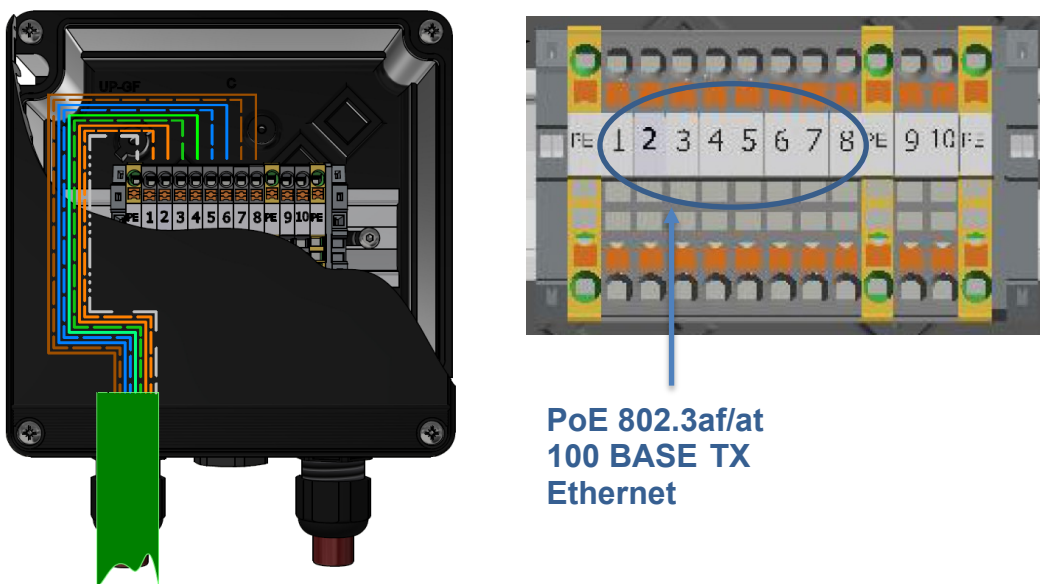

Figure 5-6 Connection to the terminal box



**Attention!**

**Introduce the foiling up to about 15 mm close to the terminals, in order to prevent alien crosstalk. Make sure that the foiling cannot cause any short circuit of the data pairs!**



**Attention!**

**Bring the twisted pair composite up to about 10 mm close to the terminals, in order to ensure interference immunity.**



**Attention!**

**Use only terminals approved by SAMCON.**



**Attention!**

**Finally, check your network installation with a Class-D Link Test.**

### 5.3 External connection and protection

There are several options of routing the ExTB-2 terminal box to a safe area:

#### 5.3.1 Direct routing from the ExTB-3 into the safe area

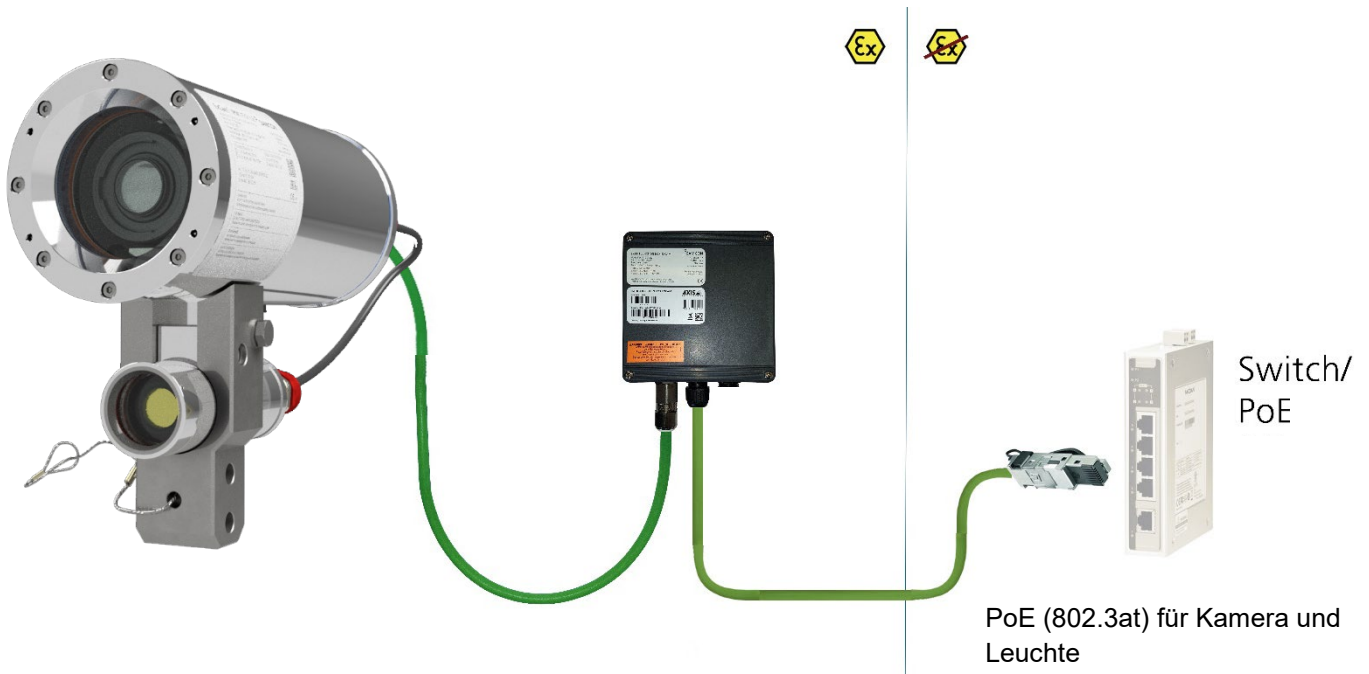

Figure 5-7 ExTB-3 -> Safe area

In the case of direct routing from ExTB-2 to the safe area, the voltage signal is led from the safe area to the terminal box. Please observe the terminal box assignment, as described above.



**Attention!**  
Cables and wires must comply with the requirements of the IEC 60079-0/1/7 & 14.



**Attention!**  
The supply line must have a sufficient cross-section. The cable protection must comply with national and international regulations.

### 5.3.2 Routing via ExConnection Rail (optional accessories)

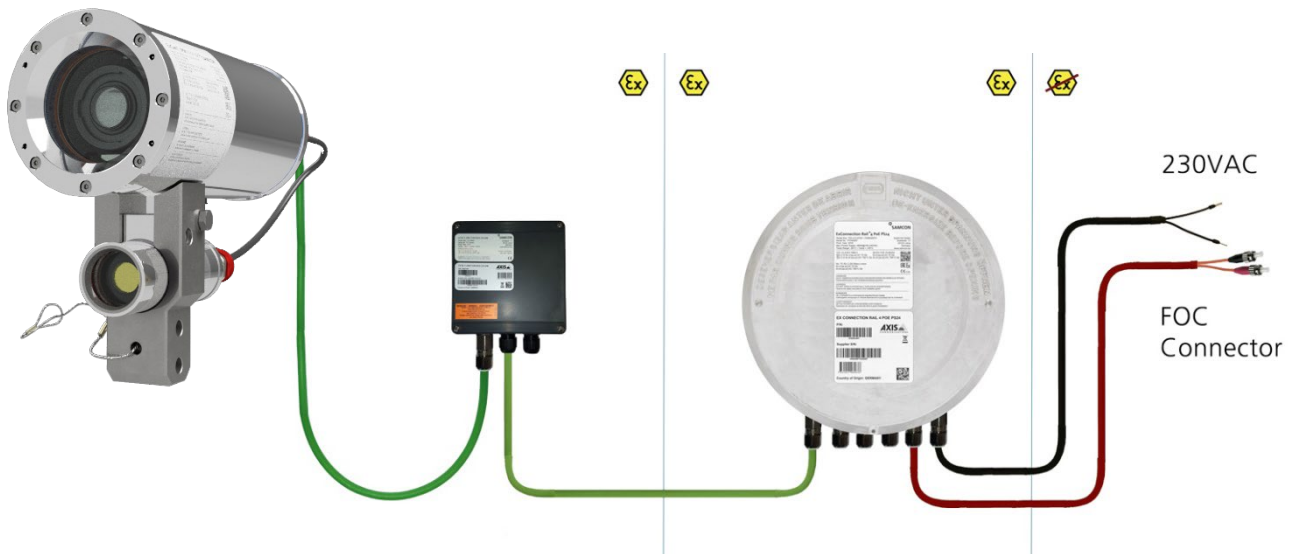

Figure 5-8 ExTB-3 -> ExConnection Rail

In the case of routing the ExTB-2 into an ExConnection Rail, larger installation distances can be managed.

**Note:**

*In hazardous areas, the ExConnection Rail (optional accessories) acts as a PoE+ switch, a media converter from copper to fibre-optic cable, as well as a power supply for the cameras.*



### 5.3.3 Appropriate cables & cable entries

An integral part of the device safety is the correct selection of the cables, wires and cable entries.



**Attention!**  
**Cables and wires must comply with the requirements of the IEC 60079-0/1/7 & 14.**



**Attention!**  
**The supply line must have a sufficient cross-section. The cable protection must comply with national and international regulations.**

For non-binding configuration and planning guidelines, please visit our website:



Perhaps our video will help you: "Cables for flameproof devices in potentially explosive atmospheres"

<http://go.samcon.eu/video-cable-ex>



Figure 5-9 Ex-d cable selection

Particularly for installations requiring a suitable barrier gland, make sure that you handle them correctly and observe the rules and notes given in the respective mounting and assembly instructions.

We show the essential procedures in the following video tutorial:

**Video Tutorial:**

Please note our video tutorial:



“SAMCON 02 Mounting and installing Ex-d barrier glands to ExConnection Rails”  
<https://go.samcon.eu/v02>



Figure 5-10 Barrier gland

### 5.3.4 Fusing

PoE power supply requires no fuses. The power supply fusing depends on the cable cross-section and length.



**Attention!**

**Please pay attention to the national and international regulations regarding selectivity and line protection.**

### 5.3.5 Plug assignments (RJ45)

The data transfer of the ExCam IPM1137-LE uses a 100 Mbit/s Ethernet connection (100BASE-TX). If the cable termination uses a plug, the latter should be plugged into the RJ45 PoE slot of the network device (PSE). Prior to connecting it to the camera, the network device (PSE) can already be supplied with power, hence there is no „power ON“ priority which has to be observed.



**Attention!**

**Use appropriate RJ45 plugs! Check the cable shielding, cross-section and the outside diameter!**



**Attention!**

**It is imperative to ensure a correct routing of the individual wires according to the EIA/TIA-568B"**



**Attention!**

**Finally, check your network installation with a Class-D Link Test.**

Detailed instructions on how to connect a RJ45 plug are available in our video tutorial: "SAMCON 03 Mounting and installing the RJ45 jack to SAMCON cables" <https://go.samcon.eu/v03>



Figure 5-11 Plug assignment, RJ45

### 5.3.6 Tests prior to switching on voltage



**Attention!**

**Prior to starting the device, perform all tests as indicated by the national regulations. Furthermore, check the correct function and installation of the device in accordance with this User Manual and other applicable regulations.**



**Attention!**

**Incorrect installation or operation of the camera may lead to a loss of warranty!**



**Attention!**

**Do not switch on the camera at temperatures below 0°C!**

## 6 Working inside the housings (Ex-d)

The customer may open the camera housing only if it is absolutely necessary. Only exchanging the SD memory card or a hardware reset are reasons for this.

The customer may open the luminaire housing only to exchange the LED-block.

### 6.1 Preparation for work:



**Attention!**

**Prepare your work carefully and in accordance with the relevant regulations.**



**Attention!**

**Depending on classification of hazard areas, it is imperative to obtain a work approval first!**

**If you adjust the camera yourself or open the pressure-resistant enclosure (Ex-d) under voltage, it is absolutely imperative to prevent potentially explosive atmosphere!**

### 6.2 Dismantling the liteServer and the cam adapter

In order to open one of the two housings, the camera and light must first be separated from each other. To do this, proceed as follows:

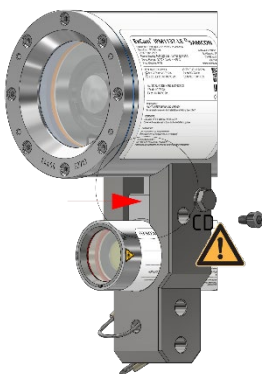

Loosen the M6 cylinder head screw and pull the liteServer forward slightly.

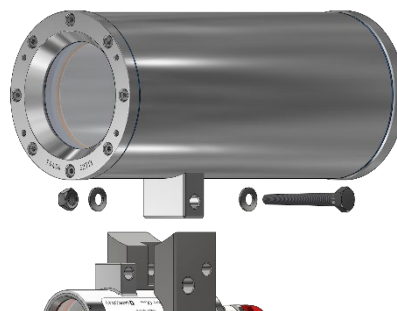

Remove M8 hexagon screw (wrench size 13). Attention: Do not lose the washer.

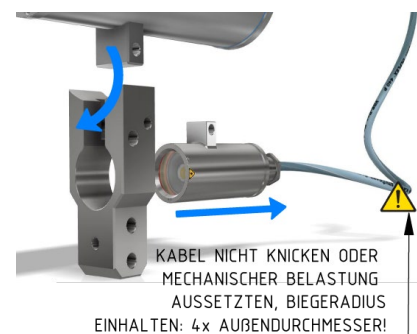

Remove cam adapter; Pull the liteServer backwards out of the adapter opening.

Figure 6-1 Disassembly of liteServer and cam adapter

## 6.3 Opening the pressure-resistant housings



### WARNING – MAY NOT BE OPENED IN HAZARD AREAS

**Note:** Depending on classification of hazard areas, it is imperative to obtain a work approval first!

Even after switching on the power supply, it is absolutely imperative to avoid potentially explosive atmosphere when opening the camera housing. Opening the housing requires disassembly and working in a safe (i.e. non-explosive!) area.



### Attention!

Pay attention not to damage the thread surface of the flame-proof gap.



### Attention!

Pay attention not to damage the housing seals. Keep them clean!

### 6.3.1 Opening the camera housing

If the ExCam IPM1137-LE is equipped with a weather protection roof this has to be removed prior to starting your work! To do so, loosen the 4x12mm button head screws M4\*0.7 at the front and rear sides of the bracket holders (Figure 6-1).

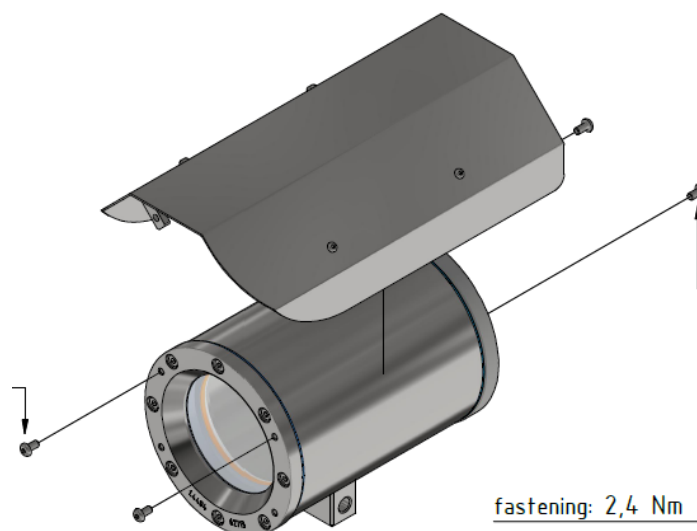

Figure 6-2 Removing the weather protection roof

To open the stainless-steel housing (T07 VA2.2.x.x) of ExCam IPM1137-LE, loosen the eight cylinder-head hexagon screws (DIN 912/ ISO 4762) together with their spring rings (DIN 127A) on the rear side of the cable and power supply flange (see Figure 6-2). Caution: do not touch the screw threads with your skin or clothes! On the threads, there is LOC-

TITE® 243™ (chemical basis is dimethacrylate ester) applied to prevent the bolted connection from unintentional loosening because of impacts and vibrations and to seal them tightly. It is not permitted for the customer to open the front-side sight glass flange! There is no need of such an action.

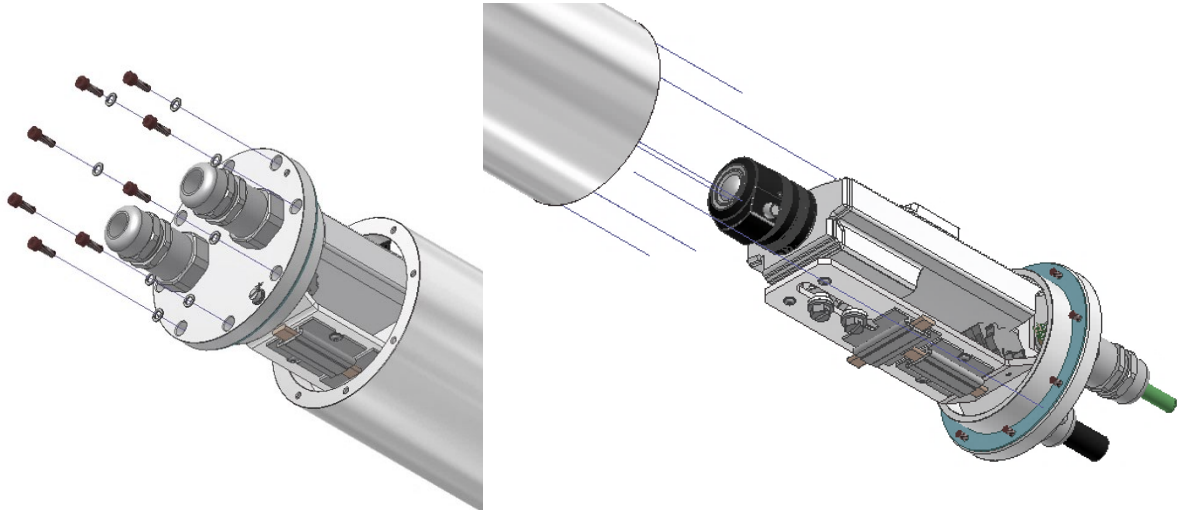

Figure 6-3 Opening the ExCam IPM1137-LE (similar illustration)

Carefully pull out the cable and supply flange to the rear, as straight as possible. Because of negative pressure, it may be difficult to remove the flange. The cylindrical clearance fit (H8f7 - DIN ISO 286) of the camera body and flange may not be tilted! Risk of damage to the flame-proof gap (DIN EN 60079-1:2012)!

Attention: The mounting adapter with the camera module and optics, as well as the temperature control, and (if applicable) auxiliary relays and terminal block are fixed on the cable and supply flange. Dealing with these components, too, you have to work very carefully and precisely in order to avoid canting and damage to the in-built components! Caution: do not touch the cylindrical fit surface with your skin or clothes! On the surface, there is oil lubricating paste to protect the surface against fretting corrosion and mechanical stresses.

When you open the housing, pay attention that you do not damage the GYLON® flat seal (blue, RAL5012) and do not make it dirty! The flat gasket is loosely attached to the cable and power supply flange. It is fixed only by the bolted connections!



**Attention!**  
**Pay attention not to damage the surface of the drill hole and the shaft (fitting) of the flame-proof gap.**



**Attention!**  
**Pay attention not to damage the housing seals. Keep them clean!**



### 6.3.2 Opening the luminaire housing

For opening the liteServer®'s pressure-resistant stainless steel housing T07 VA0.1.K1.BOR, it is mandatory to follow the step-by-step instructions as stated in the T20 Ex installation manual!

Loosen the six M3 cylinder-head hexagon screws (DIN 912/ ISO 4762) together with their spring rings (DIN 127A) on the rear side of the cable and power supply flange. Caution: do not touch the screw threads with your skin or clothes! On the threads, there is LOCTITE® 243™ (chemical basis is dimethacrylate ester) applied to prevent the bolted connection from unintentional loosening because of impacts and vibrations.

Carefully pull out the cable and supply flange to the rear, as straight as possible. Because of negative pressure, it may be difficult to remove the flange. The cylindrical clearance fit (H8f7 - DIN ISO 286) of the housing body and flange may not be tilted! Risk of damage to the flame-proof gap (DIN EN 60079-1:2012)!

Caution: do not touch the cylindrical fit surface with your skin or clothes! On the surface, there is oil lubricating paste to protect the surface against fretting corrosion and mechanical stresses.

When you open the housing, pay attention that you do not damage the GYLON® flat seal (blue, RAL5012) and do not make it dirty! The flat gasket is loosely attached to the cable and power supply flange. It is fixed only by the bolted connections!

Pull out the luminaire carefully and pay attention not to clamp the cables.

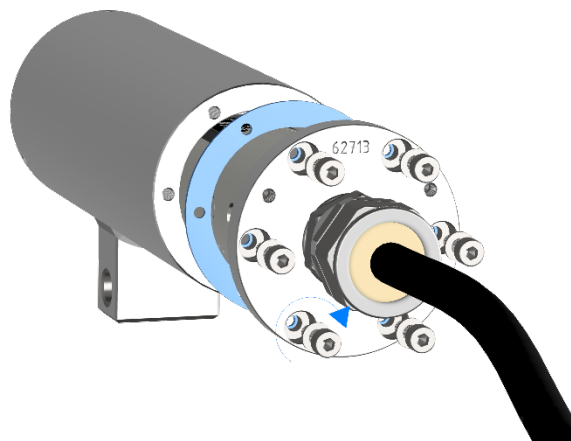

Figure 6-4 Opening the liteServer®



**Attention!**

**Beware not to damage the surface of bore hole and shaft (fit) at the flame proof gap preventing the transmission of ignition.**



**Attention!**

**Please make sure not to damage housing sealings and to keep them clean.**



## 6.4 Removing / inserting a SD memory card

### Note:

The ExCam IPM1137-LE has a slot for a micro SDHC memory card (card not included). Saved video files can be played and deleted via the web interface. They are also available in a download list. Moreover, the videos available in the memory card can also be accessed via FTP server in the network.

If the memory card has to be replaced by the user, it should be, as far as possible, empty and pre-formatted with an ext4 or vFAT file system.



**When touching electrical components, observe potential equalization (grounding of the body): carry electrostatic-discharge clothes, a PE wristband etc.!**

## 6.5 Hardware Reset

To set all the parameters of the ExCam IPM1137-LE (including the IP address) to default values, you should run a hardware reset.

The parameters can be reset via the web interface or manually. If the camera placed in the network can no longer be reached or its state is uncontrollable, the reset should be performed manually. To do so, proceed as follows:

1. Disconnect the camera installation module (Axis M1137 MKII) from the power supply.
2. Press and hold the control button (see the illustration below) and, at the same time, connect the system to the voltage supply (PoE).
3. Hold the control button pressed for about 30 seconds.
4. Release the control button. After about a minute, the AXIS M1137 MKII will return to factory defaults. If there is a DHCP server in the network, the IP address will be the following: 192.168.0.90 (subnet masking 255.255.255.0).
5. IP address and password can be redefined. If the hardware reset is not satisfactory or the network camera shows serious conflicts or does not work as usual (errors in the browser visualisation, frozen images, control commands no longer processed, slowing down of the system, etc.), it may be necessary to re-install the current firmware, or to install an update (see Chapter 7).

## 6.6 Exchanging the illuminant / LED-block

The illuminant should only be exchanged if it is defect. It must be replaced by an original spare part of the same model. In this special case it is allowed and necessary to open the Ex d housing. All required steps are described in this user manual; the descriptions stated in the T20 liteServer® Series Ex installation manual have to be observed!

Perhaps our video will help you: "Replacing the illuminant of liteServer Ex.micro"  
<http://go.samcon.eu/change-led-micro>



Figure 6.5 – Replacing the illuminant

To replace the LED-block the 2 grub screws on the side must be carefully loosened. The LED block is plugged in and can easily be removed after loosening the grub screws. Separate it at the plug contacts.

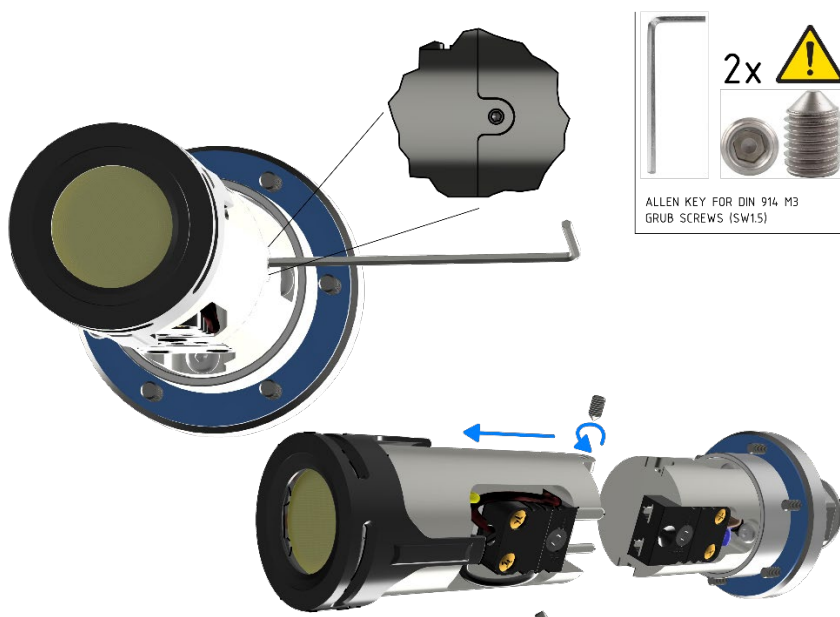

Figure 6.6 – Removal of the LED block

Insert the plug of the new LED replacement block into the connection socket off he housing flange. Make sure that the plug contacts and contact surface of the aluminium heat sink are clean and undamaged. After successfully replacing the LED block, the grub screws must be tightened again. Only use new, original grub screws. Tightening torque is 1.0 Nm! Loctite 243 may be used for screw locking.

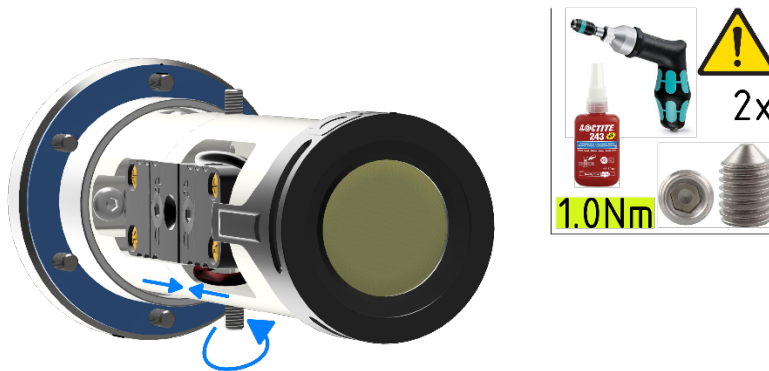

Figure 6.7 – Installation of the new LED block



**When touching electrical components, potential equalization (grounding of the body) has to be observed (ESD clothing, PE wristband etc.)!**

When closing the housing, the cable routing has to be observed! In order to avoid collisions and mechanical strain within the closed housing as well as to observe the necessary bending radius, the cable has to be looped.

## 6.7 Closing of the pressure-resistant housing

For closing the housing, proceed in reverse order as when opening. Use exclusively original screws included in the supply.

The cable and power-supply flange (K1) is fixed by 8 cylinder-head screws M4\*0.7 (ISO metric right-turning) with 12 mm thread length (DIN 912/ ISO 4762, grade 6g). Materials of bolted connections are identical to the pressure-resistant stainless steel housing (standard material no. 1.4404 AISI316L). Check whether the threaded holes are undamaged and clean. Before closing, it is also absolutely imperative to check the flame-proof gap (circular cylindrical fit).



**Attention!**

**If any mechanical damages occurred to the fitting gap, it is no longer allowed to use the housing!**



**Attention!**

**Do not lock-in any foreign objects in the housing.**



**ATTENTION!**

**Insert the flange to reach the end position, in order to ensure ignition protection and the protection level (IP) of the housing.**

Dismantled screw locks (spring washers DIN 127A) must be used again.

The GYLON® gasket must be used in undamaged condition, according to the flange hole pattern, and placed between the flange and the hull. The lateral position of the flat surface / contact surface is arbitrary. If, when closing the housing, you see that the surface of the fitting gap is dirty or insufficiently lubricated, clean it with a clean cloth and de-grease it with a suitable cleaning agent. Then re-grease it with lubricant suitable for this specific application (e.g., Molykote® P-40 gel for standard applications or special grease OKS 403 in the event of heavy seawater influence).

### 6.7.1 Closing of the camera housing

The screwed connections of flange and body components must always be tightened *crosswise* to a torque of **3 Nm**! Do not tighten the screw too strongly! It can cause rupture of the cylinder head or over-stretching the threads, and thus to impairment of the pressure resistance or ignition protection class.



**Cylinder-head bolts for explosion-proof connection of the camera body with the flange component must always be tightened at a 3 Nm torque - crosswise and evenly! Use Loctite.**

## 6.7.2 Closing of the luminaire housing

The screwed connections of flange and body components must always be tightened *cross-wise* to a torque of **1.2 Nm**! Do not tighten the screw too strongly! It can cause rupture of the cylinder head or over-stretching the threads, and thus to impairment of the pressure resistance or ignition protection class.



**Cylinder-head bolts for explosion-proof connection of the camera body with the flange component must always be tightened at a 1.2 Nm torque - crosswise and evenly! Use Loctite.**

## 6.8 Mounting the adapter and the liteServer



Push the Ex.micro through the cam adapter from behind with the optics first. Then push the cam adapter into the VA2 cam. Do not screw the liteServer tight yet!  
 First tighten the M8 screw with 20Nm.

**1**

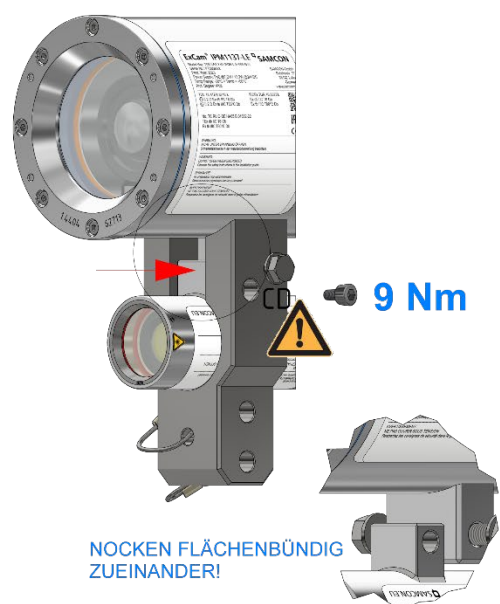

Push the VA0 cam of the liteServer flush against the VA2 cam of the ExCam. Then tighten the M6 screw with 9Nm!

**2**

Figure 6-8 Remounting the liteServer and the adapter

Use original washer. It is recommended to secure the screw connections with Loctite 243.

## 7 Network access and visualization

The most important procedures of the first starting up the camera are described below. The configuration menu of the web surface allows an intuitive navigation and offers several configuration possibilities. For detailed documentation and information how to use the web Interface, please see the User Manual for Axis or visit the following website:

<https://help.axis.com/axis-m1137-mk-ii>  
[M11 Mk II Series - User manual \(axis.com\)](https://www.axis.com/support)

The delivered ExCam IPM1137-LE is set to the applicable net frequency (50Hz or 60Hz). If the camera is used at a location with a differing net frequency, the image might start to flicker, particularly in surroundings with fluorescent tubes. In such a case, the applicable settings have to be carried out inside the menu “System Options>Advanced>Plain Config”.

User: root  
Password: root

### 7.1 Browser Support

A list of the currently supported web browsers, operating systems, required add-ons, etc. can be viewed at:

<https://help.axis.com/access-your-device>  
<https://www.axis.com/support>

### 7.2 Assigning the IP address

The ExCam IPM1137-LE is intended for use in an Ethernet network and requires an IP address to access and control it. In the most today's networks, a DHCP server is integrated. This server automatically assigns an IP address.

If there is no DHCP server available in the network, the IP default address of ExCam IPM1137-LE is “**192.168.0.90**” (subnet masking **255.255.255.0**).

With the “AXIS IP Utility”, it is possible to determine the IP address under Windows; the included USB stick contains this application.

<https://www.axis.com/support/tools/axis-ip-utility>



**If it is not possible to assign the IP address, it might be necessary to change the firewall settings!**

The "AXIS IP Utility" tool automatically recognizes all ExCam devices and visualises them in the device list. It can also be used to manually assign a static IP address. For this purpose, the ExCam IPM1137-LE network camera has to be installed in the same physical network segment (physical subnet) as the computer on which the AXIS IP Utility is running. The network signature of ExCam IPM1137-LE is "AXIS M1137 MkII" (see Figure 7-1). MAC address and serial number for clear device identification are also detected and displayed.

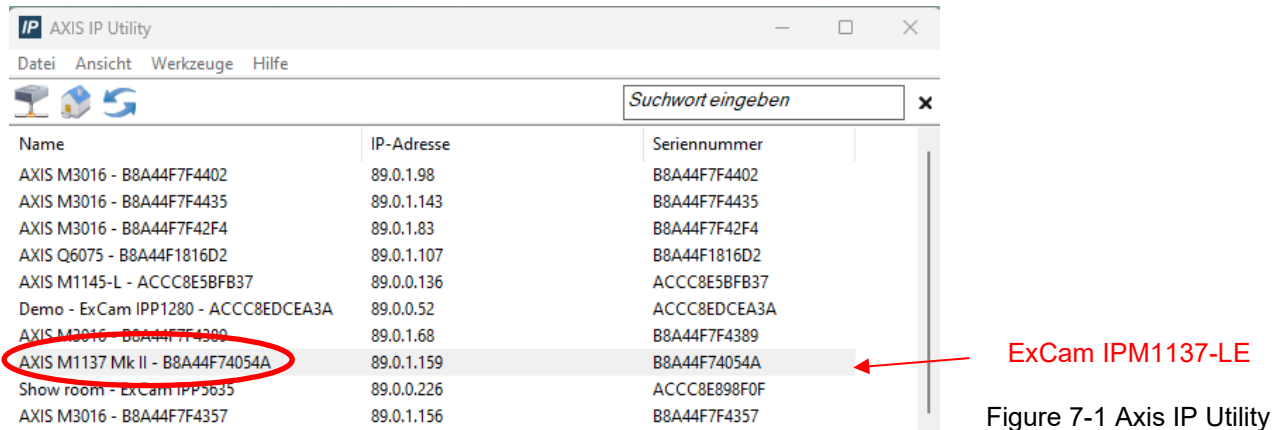

Figure 7-1 Axis IP Utility

### 7.3 Password/ Identification

The following user name is set at the factory: **root**  
 The following password is set at the factory: **root**



## 7.4 Manual or automatic control of the light via the camera

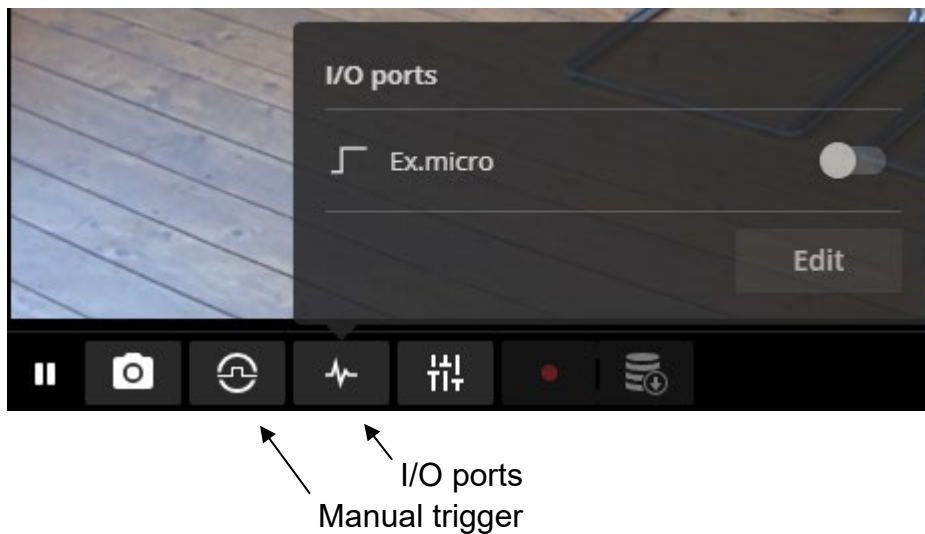

The lamp can be switched on and off manually using the I/O ports  button. To do this, configure the Ex.micro switch to “Active/inactive” using the “Edit” button.

Alternatively, the lamp can be switched on using the manual trigger  if you configure an event rule for this.

In addition, the following rules can be configured for automatic control of the Ex.micro:

- Motion detection
- Day-night mode
- according to a schedule (darkness)

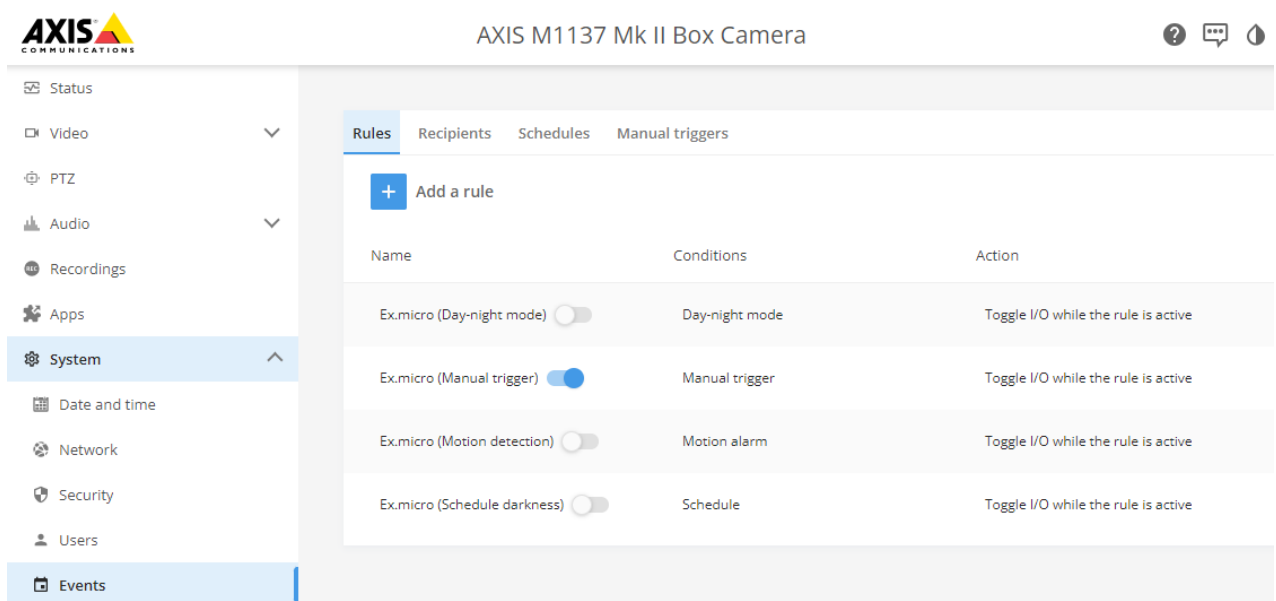



For more information about events and setting up rules for events, see:  
[AXIS M1137 Mk II User manual - Set up rules for events](#)  
[AXIS M1137 Mk II User manual - Events](#)



## 7.4.1 Event rule „Manual trigger“

### Edit rule

Use this rule

Name

Ex.micro (Manual trigger)

Wait between actions (hh:mm:ss)

00:00:00

Condition

Use this condition as a trigger

Manual trigger

Invert this condition

Channel

1 View area 1

Add a condition

Action

Toggle I/O while the rule is active

Port

Ex.micro

State

Active

Cancel

Save

## 7.4.2 Event rule „Motion detection“

To use the Motion alarm condition, the AXIS Video Motion Detection app must be installed and started.

### Edit rule

Use this rule

Name

Ex.micro (Motion detection)

Wait between actions (hh:mm:ss)

00:00:00

#### Condition

Use this condition as a trigger

Motion alarm

Source

0

Invert this condition

Add a condition

#### Action

Toggle I/O while the rule is active

Port

Ex.micro

State

Active

Cancel

Save

### 7.4.3 Event rule „Day-night mode“

#### Edit rule

Use this rule

Name

Ex.micro (Day-night mode)

Wait between actions (hh:mm:ss)

00:00:00

#### Condition

Use this condition as a trigger

Day-night mode

Mode

Day

Night

Add a condition

#### Action

Toggle I/O while the rule is active

Port

Ex.micro

State

Active

Cancel

Save

The setting sensitivity of the day-night mode can be configured under Video > Image > Day-night mode menu by adjusting the bright/dark threshold.  
If no suitable setting can be found here and the camera switches back and forth between day and night mode when the light is switched on, we recommend using a predefined schedule as an alternative.

## 7.4.4 Event rule „Schedule darkness“

In order to use the schedule, it must be configured under the System > Events > Schedules menu.

### Edit schedule

Name  
 Darkness

Recurrence  
 Daily

Start time  
 17:00 HH:MM

End time  
 07:00 HH:MM

Days

<input checked="" type="checkbox"/> Monday	<input checked="" type="checkbox"/> Friday
<input checked="" type="checkbox"/> Tuesday	<input checked="" type="checkbox"/> Saturday
<input checked="" type="checkbox"/> Wednesday	<input checked="" type="checkbox"/> Sunday
<input checked="" type="checkbox"/> Thursday	

Cancel

Save

### Edit rule

Use this rule

Name  
 Ex.micro (Schedule darkness)

Wait between actions (hh:mm:ss)  
 00:00:00

Condition

Use this condition as a trigger

Schedule  
 Schedule

Invert this condition

Schedule  
 Darkness

Add a condition

Action

Toggle I/O while the rule is active

Port  
 Ex.micro

State  
 Active

Cancel

Save

## 7.4.5 E/A-Port Ex.micro

The Ex.micro lamp is connected to the camera at port 2 and is preconfigured accordingly under the System > Accessories menu.

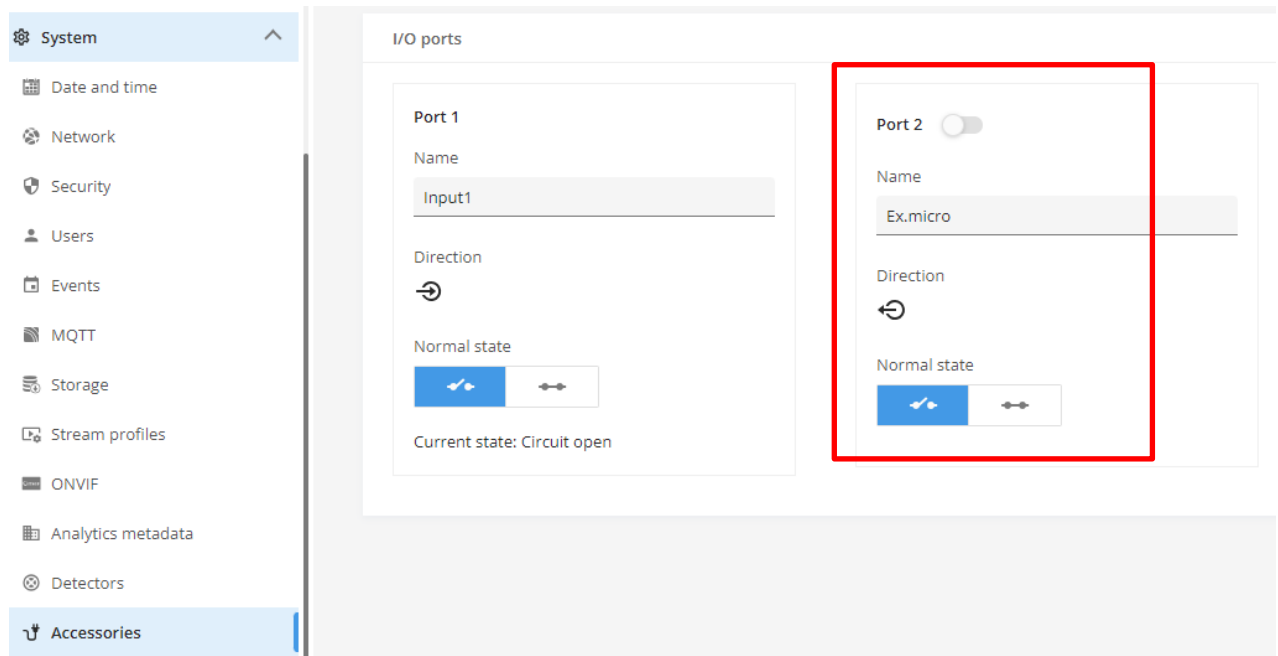

## **8 Maintenance / Modification**

The applicable regulations for the maintenance and servicing of electrical devices in potentially explosive atmospheres must be adhered to.

The required maintenance intervals are specific to the individual devices. The operating company has to determine these intervals depending on the application parameters. The maintenance tasks especially include examination of parts on which the ignition protection depends (e.g., proper condition of the casing, seals and cable entry points). If maintenance measures are necessary they have to be initiated and/or executed.

Repairs may only be carried out with original parts of SAMCON Prozessleittechnik GmbH. Damaged pressure-resistant housings have to be replaced completely. In case of doubt, send the part in question back to SAMCON Prozessleittechnik GmbH.

Reparations concerning the explosion protection must only be carried out in accordance with nationally applied regulations by SAMCON Prozessleittechnik GmbH or by an authorised electrical technician authorised by SAMCON Prozessleittechnik GmbH. Rebuilding of or alterations to the devices are not permitted.

## **9 Disposal / Recycling**

When disposing of the device, nationally applicable regulations must be observed. This Document is subject to alterations and additions.

## **10 Drawings, 3D models, certificates and further documentation**

All drawings, 3D models, certificates and other information are available in the download area of the product page on our website:

<https://www.samcon.eu/en/products/network/excam-ipm1137-le/>

Analog Ex Cameras (CVBS)	<h2 style="margin: 0;">ExCam<sup>®</sup> IPM1137-LE</h2> <p><b>The combination solution: Ex-certified high-performance camera and Ex light</b></p> <p>The ExCam IPM1137-LE combines the two devices camera and light in one. It is the ideal solution for low-light areas. A high image quality is of crucial importance in order to clearly capture a process and to be able to clearly identify the persons or objects involved. In order to optimize the performance of the camera in difficult lighting conditions (up to absolute darkness), the lighting and camera of the ExCam IPM1137-LE are optimally coordinated and the light can be easily switched via the camera.</p> <p><b>Features.</b></p> <ul style="list-style-type: none"> <li>● Broad Certification Landscape for Hazardous Areas (ATEX, IECEx &amp; more)</li> <li>● Zone 1/21, Gas Group IIC, Temperature Class T5</li> <li>● 100% Reflection-Free Camera - Light Combination</li> <li>● Single-Cable-Solution (PoE / 24VDC)</li> <li>● Versions with Visible or Infrared Light</li> <li>● Protection Level of IP66/68 (IEC 60529)</li> <li>● High Resolution: 2592x1944 (5 MP bei 25/30 fps)</li> <li>● Powerful Remote Zoom Lens (i-CS)</li> <li>● Light Control via Camera (Web Server)</li> <li>● Lightfinder and WDR Technologies</li> <li>● Object Analytics thanks to Machine Learning Processing Unit (MLPU)</li> <li>● <a href="#">Extensive Accessories</a></li> </ul> <p><b>The camera: 5 MP resolution meets a powerful remote zoom variofocus lens and MLPU</b></p> <p>The ExCam IPM1137 is a cost effective megapixel network camera, particularly suitable for use in hazardous areas. Besides 5 MP resolution (2592 x 1944) it offers a powerful remote zoom variofocus lens and a Machine Learning Processing Unit (MLPU) . It is approved according to Directive 2014/34/EU (ATEX), IECEx and EAC-Ex. These and other available approvals can be found in the download area.</p> <p><b>The world's smallest LED spotlight for hazardous areas: liteServer Ex.micro</b></p> <p>The <a href="#">liteServer Ex.micro</a> is the perfect addition to our cameras in dimly lit areas. It has a built-in, energy-efficient, long-life LED. This is optionally warm white, cold white or infrared. IR lighting (wavelength 855nm) enables unobtrusive surveillance even in total darkness. The lighting series is approved in accordance with Directive 2014/34/EU (ATEX) and IECEx.</p> <p><b>Explosion-proof IP camera with ATEX, IECEx and EAC-Ex approval</b></p> <p>The ExCam series is certified within the framework of the European (ATEX) as well as the international directive (IECEx). The explosion-proof housing is approved for ATEX group II for zones 1, 2, 21 and 22 including explosion groups IIC / IIIC. Furthermore, it now also has the EAC-Ex approval. During the development of the ExCam IPM1137, great importance was attached to safety, mechanical precision and high-quality stainless steel. In addition, a modular structure was at the forefront of the development. With regard to the technical characteristics, we have gone to the limits of what is feasible: In areas such as media resistance and ambient temperature, we are setting standards with the ExCam series.</p> <p><b>Outstanding images as a basis for reliable analysis</b></p>
Network Ex Cameras (TCP/IP)	

ExCam IPM3016
ExCam IPM1137-LE
ExCam IPM2036
ExCam IPP1275
ExCam IPP1377
coolJacket
ExCam IPQ1615 (DLPU)
ExCam IPQ1715
ExCam IPQ1785
ExCam IPP3807
ExCam IPP5655
ExCam IPQ6075
ExCam IPQ6075-MKII
ExCam IPP1280 (thermal)
ExCam XI80 (thermal)
ExCam XI410 (thermal)
Modular Ex Cameras

Robust Cameras (non-ex)
Your Individual Camera (BTO)
Ex Luminaires
Ex-d Camera Enclosures
Connection Systems
Cables for Ex-Areas
Mounting Systems
Wash and Wipe Equipment
Software

**Downloads:**

- [Comparison Chart](#)
- [Datashheet](#)
- [3D-Model \(pdf\)](#)
- [3D-Model \(stp\)](#)
- [Usermanual](#)
- [Drawing](#)
- [CAD-files \(DXF\)](#)
- [IR-Tests](#)
- [Ex Installation Manual Camera](#)
- [Ex Installation Manual Luminaire](#)
- [ATEX Type Examination](#)
- [IECEX Cert.-of-Conformity](#)
- [EAC-Ex-Certification](#)
- [MASC \(Southafrica\)](#)
- [UKEX-Certification Dec. of Conformity](#)

If you wish additional technical information, please contact us at: [support@samcon.eu](mailto:support@samcon.eu)



**SAMCON**

Schillerstrasse 17, 35102 Lohra-Altenvers,  
Germany  
[www.samcon.eu](http://www.samcon.eu), [info@samcon.eu](mailto:info@samcon.eu)  
Phone: +49 6426 9231-0, fax: - 31

